

Professional Series

Size	The template is set up at 25% of the output size and is dimensionally accurate.
Layout	Artwork must be laid out correctly as shown in the templates provided. Where there is more than one panel, if possible, avoid running text characters across the joins.
Bleed	A bleed of 2.5mm at the template size (quarter size) must be included as shown.
Scans	100dpi at the final output size is recommended. This is equivalent to 60mb per sqm of printed images. Scans should be CMYK .
Tiffs	Coloured up greyscale or bitmap tiffs should have spot colour unchecked.
Logos	Supply logos in vector format if you wish to achieve the best results.
Colour	To ensure a good match to colours please specify as Pantone colours or provide a colour swatch.
Fonts	Supply all fonts used, including fonts used in placed pictures i.e. Illustrator files. Or ensure they are saved as outlines/curves.
Proofs	Supply a hardcopy colour proof or low res pdf of the final artwork as a content guide.
Artwork Supply	Via email, upload via our site or on CD/DVD.

Important

Failure to follow the above artwork instructions may result in imperfect final output and/or extra charges to correct the artwork.



54 Hollingdean Road Brighton East Sussex BN2 4AA
t 01273 887575 f 01273 878401
e info@one-digital.com w www.one-digital.com

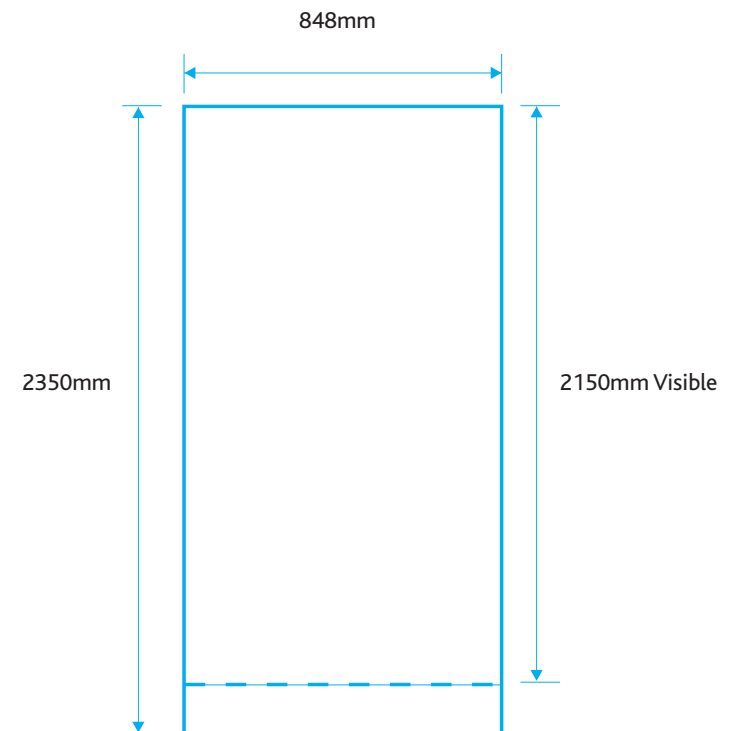

	Output Size (mm)	Artwork@25% (mm)
Pro Series Panel Size	2150(h) x 848(w)	537.5(h) x 212(w)
Non Visible Area	200mm	50mm
Total Graphic	2350(h) x 848(w)	587.5(h) x 212(w)
Bleed	10mm	2.5mm